

JUNO

PAINT MANUFACTURERS SINCE 1927

WATERPROOFING

**SYSTEMS
FOR HORIZONTAL AND VERTICAL SURFACES**





WATERPROOFING SYSTEMS for roofs, terraces and decks	4
JUNOTERAS	6
JUNOTERAS PUR	7
GOTEPUR	8

APPLICATION of horizontal system	9
1. Surface Preparation	9
1.1. Surface Pathologies.....	9
1.2. Critical areas.....	9
2. Application of a complete waterproofing system	11



WATERPROOFING SYSTEMS for façades	12
CUBREFIX	14
ELASTIFLEX	15
ELASTIFLEX PLUS	16

APPLICATION of vertical system	17
1. Surface preparation	17
2. Vertical waterproofing system	17
3. Crack-resistant system	18

Roofs, terraces and decks

HORIZONTAL SURFACES



WATERPROOFING systems for Roofs, terraces and decks

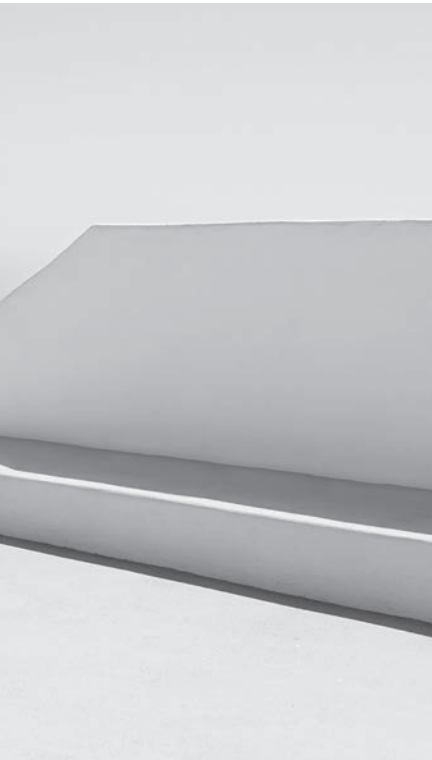

Waterproofing systems for roofs, decks and terraces are essential for protecting structures from potential water and moisture infiltration. These systems are designed to create an impermeable barrier that prevents water from entering, thus protecting the surface and extending its lifespan. There are different types of waterproofing systems, such as anti-drip elastic paints, including acrylics and elastomeric acrylics, which are the most commonly used in the market.



20% of building damage is caused by poor execution or design of the roof, even though it represents only 3% of the total investment in the building.

A good waterproofing of the roofs and decks helps improve the airtightness of the building envelope and reduces condensation and mould growth inside the home, thus directly impacting the thermal sensation and ensuring a healthy and comfortable environment.

It is important to choose the right system according to the needs of the surface to be waterproofed. Our range of waterproofing systems includes solutions to cover all waterproofing needs, depending on the substrate, its characteristics, and the requirements of the space to be treated.

Which system should I choose?

Our range of single-component waterproofing systems for horizontal surfaces offers 3 different systems to choose from, depending on the conditions of the substrate (slope and water drainage/cracks) and its usage requirements (traffic/tiled).

Condition/ usage of the surface to be treated:	Junoteras	Junoteras PUR	Gotepur
Slope	 >1%	 >1%	 ≤1%
Water evacuation	Easy	Medium	Difficult
Foot traffic	Walkable <i>(reinforced system with 160g mesh)</i>	Occasionally Trafficable <i>for maintenance (reinforced system with 225/300g mat or velobond (45 gr)</i>	Continuous Traffic <i>(System Reinforced with 225 / 300 gr Mat)</i>
Cracks	Up to 0,6 mm	Up to 0,6 mm	Up to 1 mm
Tileable	No	No	Yes

Junoteras

Elastomeric waterproof anti-leak paint



Properties

- Lightfast **colours**
- Eliminates **leakage** problems
- Excellent **adhesion** on mineral surfaces or asphalt/felt roofing
- High filling power for **cracks** and **small fissures** up to 0.6 mm
- Good **flexibility**
- High weather **resistance**
- Improves the **energy efficiency** of the surface



ADHESION	WATER VAPOUR PERMEABILITY	ANTICARBONATION
LIQUID WATER TRANSMISSION	SOLAR REFLECTANCE	FIRE-RETARDANT B-s1,d0

Ideal for surfaces with

- Slope >1%
- With easy water drainage.
- Walkable
- With cracks up to 0.6 mm width

Use	Exterior
Finish	Semi-matt
Colour	White (62.641), Red (62.642), Green(62.643), Grey (62.644), Tile red (62.645) and Black (62.654) Waterproofing colour card
Practical coverage	2 L/ m ² (1 mm)
Touch dry	2 hours
Min/max repaint time:	24 hours/ Unlimited
Thinning & cleaning	Water

Formats: 4L & 15L

Recommendation

Recommended for the waterproofing of terraces and decks, provided there is a water drainage slope of more than 1% and/or cracks smaller than 0.6 mm. It is also particularly suitable for eliminating moisture problems in hard-to-reach areas not exposed to continuous foot traffic.

System selection based on substrate type

After preparing the surface (see page 9), the system to apply is chosen based on substrate type and its condition.

SURFACE	CEMENTICIOUS/ NEW CONCRETE	CEMENTITIOUS/ EXISTING CONCRETE	CERAMIC	METAL	FIBRECEMENT	ASPHALT FELT
PRIMER	Primerlite (21.702) / Akрил 80 (42.115)	Junoteras diluted 20%	Dynapok Agua Floors (07.132) diluted 10%	Dynapok Zinc Phosphate Primer (22.722)	Junoteras diluted 20%	Dynapok Agua Floors (07.132) diluted 10%
1 st COAT	Junoteras + mesh 160 gr					
2 nd COAT	Junoteras					
3 rd COAT	Junoteras Finish with 2 or more coats of paint until the mesh is completely covered, ensuring a minimum practical coverage of 2 L/m ² for the complete system.					

* Warranty only applicable to reinforced systems. The use of mesh and a minimum thickness of 1 mm are required.

Junoteras PUR

Polyurethane elastomeric waterproof antileak paint



Properties

- Eliminates **leakage** problems
- Excellent **adhesion** on mineral surfaces or bituminous felt
- High filling power for **cracks** and **small fissures** up to 0.6 mm
- Good **elasticity**
- Minimal **water absorption**
- Good **mechanical** properties
- Good UV **resistance**



Use	Exterior
Finish	Semi-matt
Colour	White (62.831) & Red (62.832) Waterproofing colour card
Practical coverage	2 L/ m ² (1 mm) reinforced system 1,8 L/ m ² (1 mm) non-reinforced system
Touch dry	2 hours
Min/max repaint time:	24 hours/ Unlimited
Thinning & cleaning	Water

Formats: 4L & 15L

ADHESION	WATER VAPOUR PERMEABILITY	ANTICARBONATION
LIQUID WATER TRANSMISSION	SOLAR REFLECTANCE	FIRE-RETARDANT B-s1,d0
RESISTANCE TO STATIC/DYNAMIC LOAD	CRACK RESISTANCE CLASSA3	

Recommendation

Recommended for waterproofing terraces and slabs with cracks up to 0.6 mm, provided there is a water drainage slope greater than 1%. It is also particularly suitable for resolving moisture issues in hard-to-reach areas that are not exposed to continuous foot traffic (though occasional traffic is acceptable) and where minimal water absorption is required.

System selection based on substrate type

After preparing the surface (see page 9), the system to apply is chosen based on substrate type and its condition.

Ideal for surfaces with

- Slope >1%
- So me water run-off difficulty
- Occasional foot traffic
- Cracks up to 0,6 mm width

SURFACE	CEMENTICIOUS/ NEW CONCRETE	CEMENTITIOUS/ EXISTING CONCRETE	CERAMIC	METAL	FIBRECEMENT	ASPHALT FELT
PRIMER	Primerlite (21.702) / Akрил 80 (42.115)	Junoteras diluted 20%	Dynapok Agua Floors (07.132) diluted 10%	Primer Dynapok zinc phosphate (22.722)	Junoteras diluted 20%	Dynapok Agua Floors (07.132) diluted 10%
1'st COAT	Junoteras PUR + velobond 45 gr or 225 / 300 gr mat (If the system is not reinforced, the surface will only be walkable, not suitable for occasional foot traffic.)					
2'nd COAT	Junoteras PUR					
3'rd COAT	Junoteras PUR Finish with 2 or more coats of paint until the mesh is completely covered, ensuring a minimum practical coverage of 2 L/m ² for the complete system.					

* Warranty applies only to reinforced systems. The use of mat or Velobond and a minimum thickness of 1 mm is essential.

Gotepur

100% polyurethane-based elastomeric waterproofing membrane



Properties

- Excellent **waterproofing** and mechanical properties
- High **resistance to UV** rays
- **Perfect adhesion** to mineral surfaces or bituminous felts
- High filling capacity for cracks and small fissures up to 1 mm. **Class (A4)**
- Maximum **elasticity**
- Maximum resistance to **stagnant water**
- Effective **carbonation barrier**



RESISTANCE TO STATIC/DYNAMIC LOAD	WATERTIGHTNESS	LIQUID WATER TRANSMISSION
ADHESION	WATER VAPOUR PERMEABILITY	CRACK RESISTANCE CLASS A4
		SOLAR REFLECTANCE

Ideal for surfaces with

- Minimal slope gradient
- With difficult water drainage
- Continuous foot traffic
- With cracks up to 1 mm
- Suitable for tiling

Use	Exterior
Finish	Semi-matt
Colours	White (62.895) & Red (62.894) Waterproofing colour card
Practical coverage	2L/ m ² (1 mm)
Touch dry	2 hours
Min./Max. repaint time:	24 hours/ Unlimited
Thinning & cleaning	Water

Format: 15L

Recommendation

Recommended for waterproofing terraces and slabs exposed to continuous foot traffic. Particularly suitable for resolving moisture issues on surfaces with minimal slope, requiring maximum resistance to stagnant water, as well as on substrates with cracks up to 1 mm. Suitable for tiling.

System selection based on substrate type

After preparing the surface (see page 9), the system to apply is chosen based on substrate type and its condition.

SURFACE	CEMENTICIOUS/ NEW CONCRETE	CEMENTITIOUS/ EXISTING CONCRETE	CERAMIC	METAL	FIBRECEMENT	ASPHALT FELT
PRIMER	Primerlite (21.702) / Akрил 80 (42.115)	Junoteras diluted 20%	Dynapok Agua Floors(07.132) diluted 10%	Primer Dynapok Zinc phosphate (22.722)	Junoteras diluted 20%	Dynapok Agua Floors (07.132) diluted 10%
1'st COAT	Gotepur + matt of 225 / 300 gr					
2'nd COAT	Gotepur					
3'rd COAT	Gotepur					
	Finish with two or more coats of paint until the mat is completely covered, ensuring a minimum practical coverage of 2 L/m ² for the entire system.					

* Guarantee applies only to reinforced systems. The use of mat and a minimum thickness of 1 mm is essential.

Application of the horizontal system

1 Surface preparation

Proper surface preparation is essential for the application of liquid waterproofing systems to ensure greater durability of the system. Depending on the type and condition of the substrate, different preparation methods may be required.

1.1. Most common substrate pathologies

A crucial aspect of surface preparation is identifying and addressing any pathologies present in the substrate. At JUNO Paints, we can provide expert technical advice in this field.

Residual paint or previous membranes	Lack of leveling	Contamination	Dirt	Cracks and fissures
				
Completely remove using sandblasting or with JUNO Paint stripper.	If leveling exceeds 1 cm, use an appropriate mortar for proper leveling.	Clean with pressurized water and detergent, rinse well, and allow the surface to dry completely.		See page 17

1.2. Treatment of critical areas

Before applying the liquid waterproofing to a roof surface, attention must be given to critical areas such as plinths, drains, downspouts, chimneys, vertical junctions, etc.

PLINTHS – HALF ROUND MOLDINGS

All junctions between horizontal and vertical surfaces (internal and external corners).

- 1) Surface preparation: Surface must be consolidated, clean, and dry. Remove any remaining paint or previous membranes. Proceed by sanding and then vacuum. Secure any loose tiles or elements, and fill gaps with waterproof mortar or polyurethane sealant..
- 2) Prime with a roller, approximately 20 cm on both horizontal and vertical surfaces at the edge. (Choose primer based on the type of substrate).
- 3) Form a quarter-round molding with polyurethane sealant or waterproof mortar at all vertical junctions of the substrate to eliminate any right angles.
- 4) Apply the first coat of the chosen waterproofing product (depending on the substrate type), reinforced with a 160 g/m² mat, overlapping mats 5 to 10 cm if necessary.
- 5) Apply one or more coats of the chosen waterproofing (depending on the substrate type) across the entire surface, avoiding air bubble formation and fully covering the mat underneath.

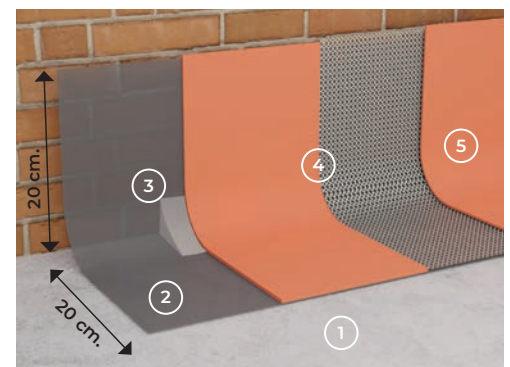

DRAINS AND SUMPS

- 1) Surface preparation: Surface must be consolidated, clean, and dry. Remove any remaining paint or previous membranes. Proceed by sanding and then vacuum. Secure any loose tiles or elements, and fill gaps with waterproof mortar or polyurethane sealant.
- 2) Prime with a roller, approximately 15 cm around the drain. (Choose primer based on the type of substrate).
- 3) Fill the gap between the downspout and the floor with polyurethane sealant or waterproof mortar.
- 4) Apply the first coat of the chosen waterproofing (depending on the type of substrate), reinforced with a 160 g/m² mat in a flower petal pattern around the drain, overlapping each strip.
- 5) Apply one or more coats of the chosen waterproofing (depending on the type of substrate) across the entire surface, avoiding the formation of air bubbles and fully covering the mat.

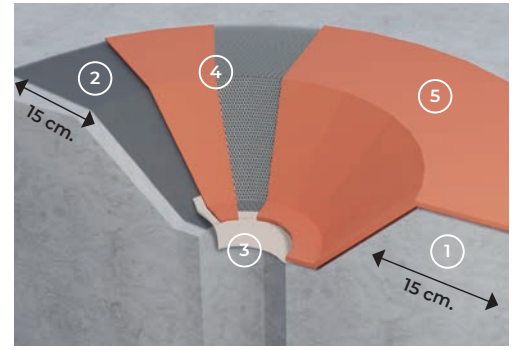

EXPANSION JOINTS, CRACKS, AND FISSURES

Joint in the flooring designed to absorb the structural movements of the building.

- 1) Surface preparation: Surface must be consolidated, clean, and dry, removing any remnants of paint or previous membranes. Proceed by sanding and then vacuuming. Secure any loose tiles or elements, and fill gaps with waterproof mortar or polyurethane sealant.
- 2) Prime with a roller, approximately 15 cm on each side of the expansion joint. (Choose primer based on the type of substrate).
- 3) Fill the expansion joint with polyurethane sealant or waterproof mortar.
- 4) Apply the first coat of the chosen waterproofing (depending on the type of substrate), reinforced with a 160 g/m² mat, loosely placed inside the expansion joint.
- 5) Apply one or more coats of the chosen waterproofing (depending on the type of substrate) across the entire surface, avoiding the formation of air bubbles and fully covering the mat.

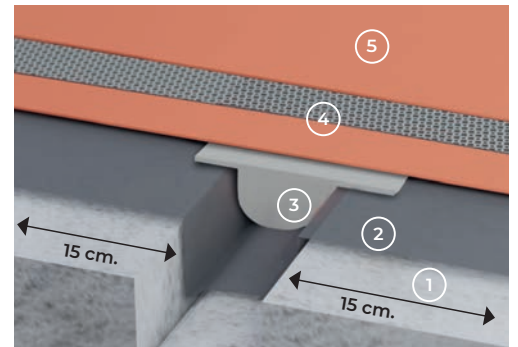

DRAINAGE PIPES

- 1) Surface preparation: Surface must be consolidated, clean, and dry, removing any remnants of pipe or previous membranes. Proceed by sanding and then vacuuming. Secure any loose tiles or elements, and fill gaps with waterproof mortar or polyurethane sealant.
- 2) Prime with a roller, approximately 20 cm on both the horizontal and vertical surfaces of the drainage pipe.
- 3) Form a quarter-round molding with polyurethane sealant or waterproof mortar.
- 4) Apply the first coat of the chosen waterproofing (depending on the type of substrate), reinforced with a 160 g/m² mat, overlapping mat strips 5 to 10 cm, reinforcing all junctions with pipes or other elements that penetrate the substrate.
- 5) Apply one or more coats of the chosen waterproofing (depending on the type of substrate) across the entire surface, avoiding air bubble formation and fully covering the mat.

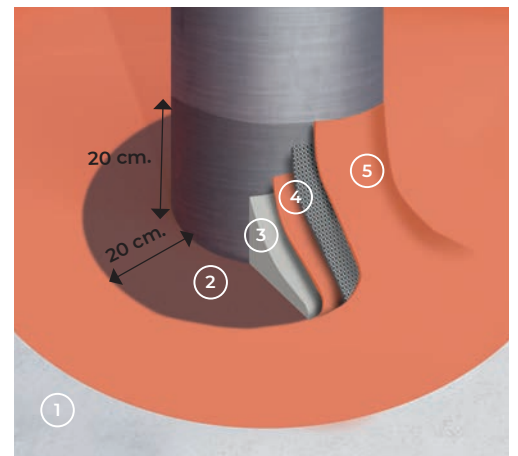

REINFORCING CRITICAL AREAS:

Application of waterproofing on critical areas must be carried out by respecting the re-coat intervals between successive coats until the required coverage is achieved according to the waterproofing system. (see TDS for correct re-coat time intervals).

Distribute the product evenly across the entire substrate, aiming to leave the surface as level as possible.



2 Reinforcement of a complete horizontal waterproofing system

The reinforcement allows for the absorption of structural movements of the roof, acting as an “anticrack” membrane. Additionally, it helps to level the surface and increases adhesion to the substrate, preventing wear in localized areas that could become points of water infiltration.

After treating the key critical areas, proceed with the waterproofing of the entire surface.

1 Surface preparation:

Thorough cleaning is required to remove any remnants of oil, grease, efflorescence, solid debris, dust, and other contaminants that could prevent proper adhesion of the system.

It is recommended to use mechanical methods (sanding, vacuuming) and avoid using water as much as possible. If water is used, it is essential to allow the area to dry before proceeding with priming.

2 Priming with a roller (choose the indicated primer based on substrate type).

3 Apply the first coat of undiluted waterproofing.

Use a short-pile roller for deckings and apply product evenly across the entire substrate.

While the first coat is still fresh, place the reinforcement element (mat, mesh, Velobond) with an overlap of 5-10 cm, and compact it with the roller to allow trapped air to escape outward. Ensure the reinforcement element is properly laid, stretched and free of wrinkles.

4 After 24 hours, apply a new coat of waterproofing across the entire surface, ensuring that the mat/mesh/Velobond is completely covered. Finish with two or more coats of paint, ensuring a minimum practical coverage rating/ consumption of 2 L/m² for the entire system.

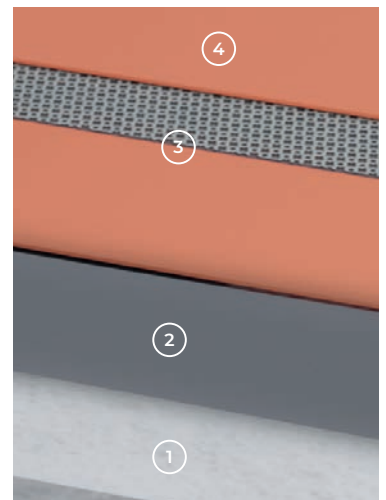

Facades Walls Partition walls Patios & Light shafts

VERTICAL SURFACES

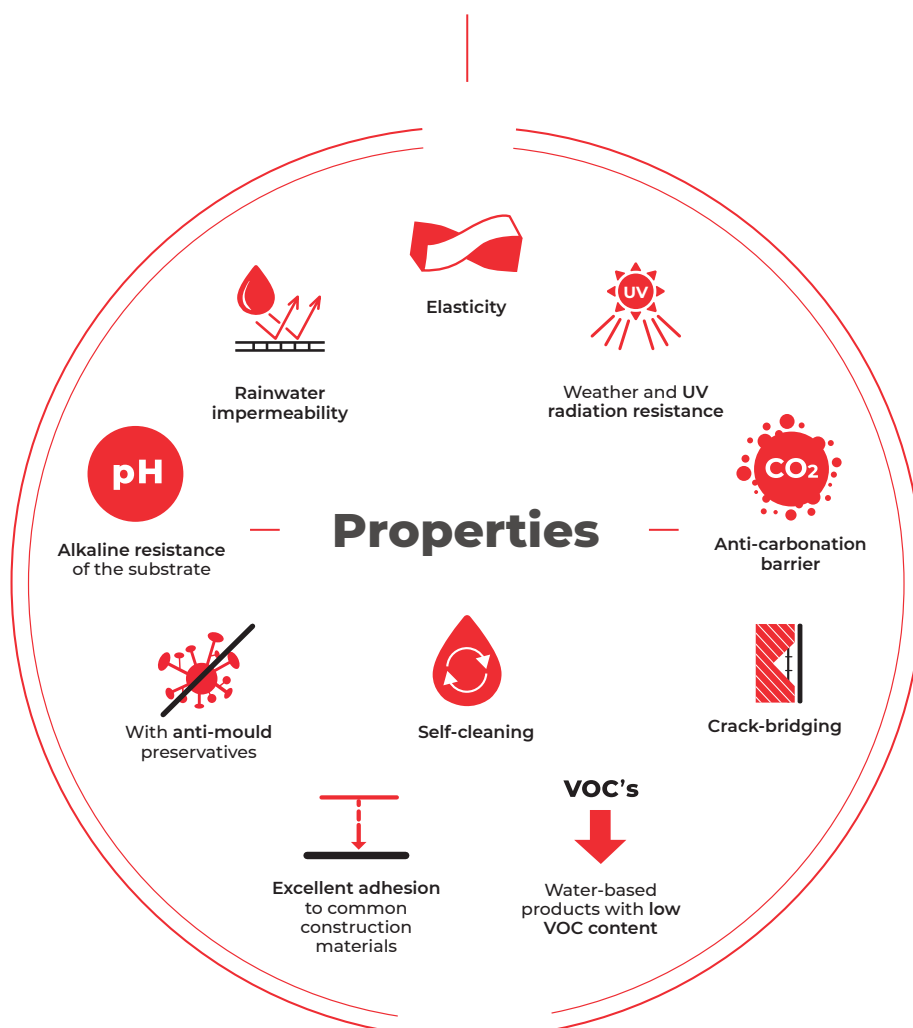



WATERPROOFING systems for facades

Waterproofing systems for facades are essential for protecting the structure, preventing leaks and moisture, and enhancing the insulation and energy efficiency of a building.

Waterproof paint creates a barrier that prevents water from infiltrating the structure, helping to avoid issues such as mould, cracks, and facade damage. Additionally, it helps maintain the facade's aesthetic appearance and prolongs its lifespan.

It is important to choose the right system based on the needs of the surface to be waterproofed.

Our range of waterproofing systems includes solutions for all waterproofing requirements, depending on the substrate, its characteristics, and the specific needs of the space to be treated.

Which system should I choose?

Our range of waterproofing systems for vertical surfaces includes 3 different options to choose from, depending on the substrate conditions, with particular attention given to cracking.

Condition/use of the surface to be treated:	Cubrefix	Elastiflex	Elastiflex Plus
Elasticity	Medium	Maximum	Maximum
Colours	White	White, Red & Tinting Systems	White
Cracks	Up to 0,2 mm	Up to 1,5 mm	Up to 4 mm
Photocurable	No	Yes	Yes

Cubrefix

Elastomeric waterproofing paint



Properties

- With anti-mould preservatives
- Waterproofing properties
- High filling power for micro-cracks
- High opacity
- Elimination of moisture problems on walls
- Good elasticity



Use	Interior - exterior
Finish	Mate
Colour	White (62.875) Waterproofing colour card
Practical coverage	8-10 m ² / L per coat (for micro-cracks up to 0.2 mm)
Touch dry	2 hours
Min./Max. repaint time:	24 hours/ Unlimited
Thinning & cleaning	Water

Formats: 4L & 15L

Recommendation

Recommended for the vertical waterproofing of facades, walls, partition walls, and light shafts. Especially suitable for surfaces with micro-cracks up to 0.2 mm.

System selection based on substrate type

After preparing the surface (see page 17), we will choose the system to apply based on the type of substrate and its condition.

SURFACE	CONCRETE, CEMENT MORTAR, PAINTED WALLS	FAÇADE BRICK, CERAMIC FINISH
PRIMER	Primerlite (21.702) /Akriil 80 (42.115)	Consult with Technical Department
TOPCOAT (2 or 3 coats)	Cubrefix	



Suitable for walls with micro-cracks

Microcracks





* The warranty applies to a painting system validated by, and applied according to JUNO's instructions, not extending the warranty to the application itself. Consult conditions with the Technical Department.

Elastiflex

Certified elastomeric waterproofing paint for cracks up to 0.9 mm, capable of withstanding cracks up to 1.5 mm.

Properties

- With anti-mould preservatives
- Excellent waterproofing and mechanical properties
- High filling power for cracks and small fissures up to 2 mm
- Maximum elasticity
- Elimination of moisture problems on facades
- Effective carbonation barrier, breathable
- 100% acrylic, photocurable

Use	Exterior
Finish	Mate
Color	White Base/P (62.601), Deep Base/TR (62.695) & Red (62.602)
	 
Practical coverage	6-7 m ² /L in two coats (for cracks up to 0.9 mm)
Touch dry	2 hours
Min./Max. repaint time:	24 hours/ Unlimited
Thinning & cleaning	Soap & water

Formats: 4L & 15L

Recommendation

Recommended for the vertical waterproofing of facades, walls, partition walls, patios and light shafts. Especially suitable for surfaces with cracks ranging from 0.9 to 1.5 mm.

System selection based on substrate type

After preparing the surface (see page 17), we will choose the system to apply based on the type of substrate and its condition.

SURFACE	CONCRETE, CEMENT MORTAR, PAINTED WALLS	FAÇADE BRICK, CERAMIC FINISH
PRIMER	Primerlite (21.702) /Akriil 80 (42.115)	Consult with Technical Department
TOPCOAT (2 or 3 coats)	Elastiflex	



EPD®
THE INTERNATIONAL EPDP SYSTEM

ADHESION

WATER VAPOUR PERMEABILITY

ANTICARBONATION

LIQUID WATER TRANSMISSION

SOLAR REFLECTANCE

FIRE-RETARDANT B-s1,d0

CRACK RESISTANCE CLASS A4

Ideal for walls with cracks up to 1.5 mm.

Cracks up to 1,5 mm

* The warranty applies to a painting system validated by, and applied according to JUNO's instructions, not extending the warranty to the application itself. Consult conditions with the Technical Department.

Elastiflex Plus

Elastomeric waterproofing paint certified for cracks up to 2 mm, capable of withstanding cracks up to 4 mm.

Properties

- With anti-mould preservatives
- Excellent waterproofing and mechanical properties
- High filling power for cracks and small fissures up to 4 mm
- Maximum elasticity
- Elimination of moisture problems on walls
- Effective carbonation barrier, breathable
- 100% acrylic, photocurable



Use	Exterior
Finish	Matt
Colour	White (62.767) Waterproofing colour card
Practical coverage	5-6 m ² /L in two coats (for cracks up to 2.6 mm)
Touch dry	2 hours
Min./Max. repaint time:	24 hours/ Unlimited
Thinning & cleaning	Soap & water

Format: 15L

Recommendation

Recommended for the vertical waterproofing of facades, walls, partition walls, patios and light shafts. Especially suitable for surfaces with cracks ranging from 2 to 4 mm.

System selection based on substrate type

After preparing the surface (see page 17), we will choose the system to apply based on the type of substrate and its condition.

SURFACE	CONCRETE, CEMENT MORTAR, PAINTED WALLS	FAÇADE BRICK, CERAMIC FINISH
PRIMER	Primerlite (21.702) /Akril 80 (42.115)	Consult with Technical Department
FINISH (2 or 3 coats)	Elastiflex Plus	



ADHESION	WATER VAPOUR PERMEABILITY	ANTICARBONATION
LIQUID WATER TRANSMISSION	SOLAR REFLECTANCE	FIRE-RETARDANT B-s1,d0
		CRACK RESISTANCE CLASS A5

Ideal for walls with cracks up to 4 mm

Cracks up to 4 mm

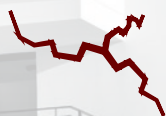

* The warranty applies to a painting system validated by, and applied according to JUNO's instructions, not extending the warranty to the application itself. Consult conditions with the Technical Department.

Application of the vertical system

1 Surface preparation

It is essential to review the general condition of the walls before starting to paint, paying special attention to any potential issues with the substrate, as well as the condition of the existing paint.

- Remove any loose particles from the substrate.

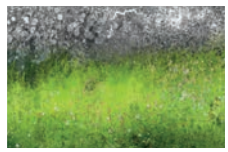

Mould, moss, fungi

- If microorganisms (mold, moss, fungi) are present, wash the surface with **Junoclean (Prod.Code 760.180)**. Once applied, rinse with water and allow to dry completely.

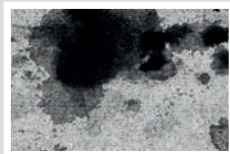

Grease

- Grease or oil residues must be completely removed with detergents.
- Rinse with water and allow to dry completely.



Efflorescence

- Remove **efflorescence** by brushing and washing the surface with a solution of 10% hydrochloric acid or 10% zinc sulfate. Rinse with water and allow to dry completely.



Friable/Chalky surfaces

- For **old/friable/chalky paints**, remove the surface residues using pressure washing, allow the surface to dry completely, and then apply a primer with **Hidrocril (cod. 81.006)** to consolidate the surface.



Unevenness

- Address any **uneven areas** to level the surface. These irregularities should not exceed 1 cm. If present, use an appropriate mortar for proper leveling.



Cracks

- In the case of cracks or fissures:

If they are less than 0.6 mm: clean, remove efflorescences, mould, and allow to dry completely.

If they are greater than 0.6 mm: widen them in a wedge shape, remove dust, and apply **Primerlite (code 21.702)** or **Hidrocril (code 81.006)** before filling with **JUNO acrylic filler (code C71.111)** and finishing with **Plaste RAP filler (code 77.301)**.

2 Vertical waterproofing system

After preparing the facade surface, apply the chosen system based on the table on page 13, and apply the primer and finishing coats with the specified coverage rates for each product.

3 Anti-crack system

In the case of walls with cracks up to 2 mm covering more than 30% of the surface, an anticrack system (consisting of a mortar reinforcement with mesh) will be necessary.

1° Mesh Reinforcement

- 1 When the substrate is clean and properly treated as previously mentioned, the surface will be coated with a first coat of **JUNOTherm® MRT-100 cement-based render (Prod. code 77.600)** using an 8x8 mm stainless steel trowel, achieving a thickness of **2-3 mm**.
- 2 While the rendering mortar is still wet, fully embed the **JUNOTherm® 160gr mesh (code 800.257)**. The mesh should be placed in the outer third of the mortar layer, allowing the grid pattern to be slightly visible.

At mesh joints, there should be a minimum overlap of 10 cm.

- 3 Once the mortar layer and mesh have hardened and dried, apply a second 1-2 mm thick coat of **JUNOTherm® MRT-100 (code 77.600)** to completely cover the mesh, ensuring a smooth, floatfinished surface free of marks and with a uniform texture throughout.

2° Primer

- 4 Before applying the finishing coat, the surface must be primed with **Primerlite (code 21.702)** or **Akril 80 (code 42.115)** to enhance adhesion, regulate the substrate's absorption, reduce the risk of efflorescence, and improve the uniformity of the final colour.

3° Topcoat

- 5 Once the primer coat is dry, the final finishing coat can be applied. Finish with two coats of **waterproof wall paint** until reaching the required dry film thickness specified for each product in this catalogue.

- Cubrefix: 8-10 m²/L
- Elastiflex: 6-7 m²/L
- Elastiflex Plus: 5-6 m²/L

It is also possible to finish the system with **EVOKRIL acrylic waterproofing mortar** or **EVOKRIL SLX siloxane-based mortar**.

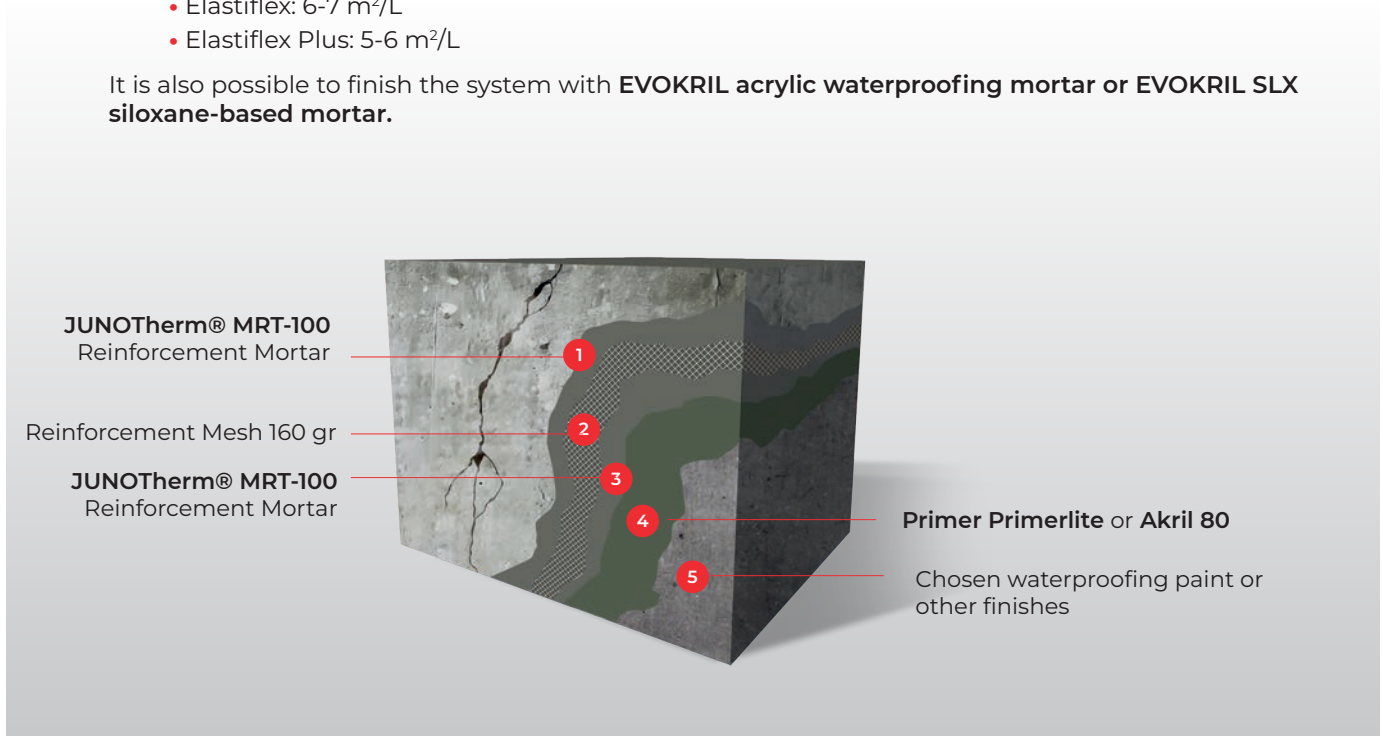

More information

www.juno.es

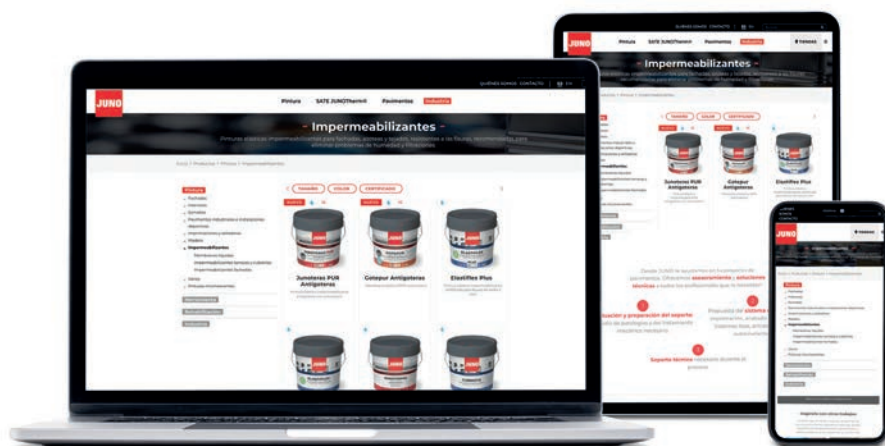

 Tfno: +34 944 670 062

 infoweb@juno.es





PAINT MANUFACTURERS SINCE 1927

Barrio Saconi, 10 - 48950 Erandio (Bizkaia) - SPAIN
Tfno.: +34 944 670 062

infoweb@juno.es

www.juno.es

